

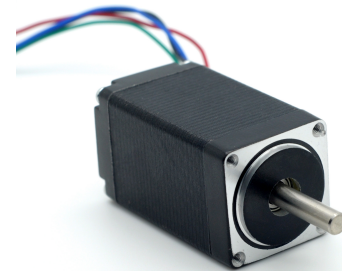

Step Angle	1.8° (+/-5% @ full step, no load)
Resistance Accuracy	+/-10%
Inductance Accuracy	+/-20%
Temperature Rise	80DegreeC MAX.
Ambient Temperature	-20 ~ +50 DegreeC
Shaft Radial Play	0.02MAX @ 450g-load
Shaft Axial Play	0.08MAX @ 450g-load
MAX Radial Force	28N @ 20mm from the flange
MAX Axial Force	10N
Dielectric Strength	500VAC for one minute
Insulation Resistance	MIN 100Mohms, 500VDC

28 mm Series (NEMA 11 size)
1.8Degree High Torque Type



Model		Rated Voltage	Current /Phase	Resistance /Phase	Inductance /Phase	Holding Torque	Leads Number	Rotor Inertia	Approx. Weight	Body Length
Single Shaft	Double Shaft									
LDO-28STH***		V	A	ohms	mH	g.cm		Kg.m ²	Kg	mm
***32-0956A	***32-0956B	2.66	0.95	28	0.8	430	6	9x10 ⁻⁷	0.11	31.5
***32-0674A	***32-0674B	3.8	0.67	5.6	3.4	600	4			
***45-0956A	***45-0956B	3.4	0.95	3.4	1.2	750	6	12x10 ⁻⁷	0.14	44.5
***45-0674A	***45-0674B	4.56	0.67	6.8	4.9	950	4			
***51-0956A	***51-0956B	4.4	0.95	4.6	1.8	900	6	18x10 ⁻⁷	0.2	50.5
***51-0674A	***51-0674B	6.2	0.67	9.2	7.2	1200	4			

(Model format: LDO-28STH51-0674A)

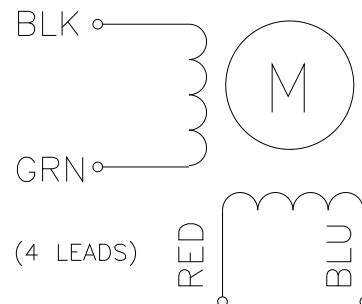
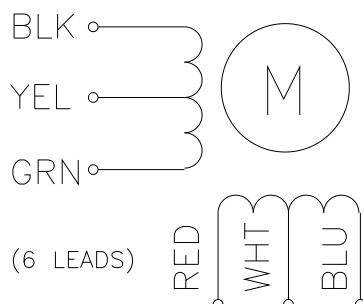
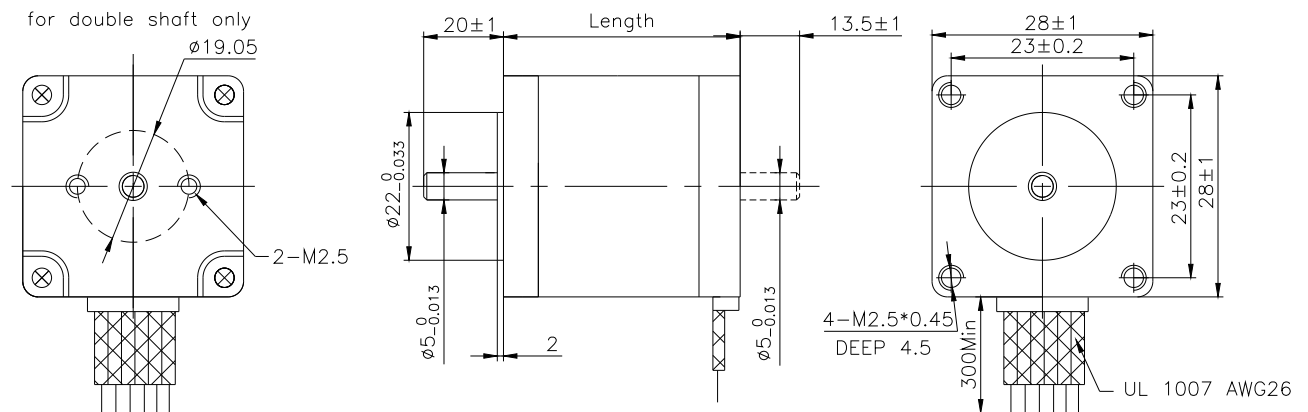

Note: NEMA8,11,14,15,17,23,34,43 size are available for stepper motors, and 0.9Degree Stepper is also available.